

NOTES

1. Provide with temperature display and communications ports.

BILL OF MATERIAL

DESIG	QTY	MODEL NO.	DESCRIPTION
TS 1	1		Temp Sensor, Zone
TS 2	1		Temp Sensor, Duct
CS1	1		Current Switch

POINTS LIST

POINT NAME	POINT DESCRIPTOR	POINT TYPE				REMARKS
		DI	AI	DO	AO	
HPxx.COMP-C	HPx Compressor S/S			1		
HPxx.REV-C	HPx Reversing Valve			1		
HPxx.ELE-C	HPx Electric Heat			1		
HPxx.S-FN-C	HPx SF Start/Stop			1	1	
HPxx.S-FN-STS	HPx SF Status	1				
HPxx.SA-T	HPx SA Temperature		1			
HPxx.ZN-xx-T	HPx Zone xx Temp		1			
HPxx.ZN-xx-T-SP	HPx Temp Set Point		1			
HPxx.OCC-OVRD	HPx Occ Override	1				
HPxx.OCC-SENS	HPx Occ Sensor	1				
TOTALS		3	3	4	0	

SEQUENCE OF OPERATION

General: The heat pump unit shall be fully controlled by the BAS.

Space Temperature Control: During periods of occupied operation (space is occupied, scheduled to be occupied or occupancy is detected) the operator may adjust the Normal (72F adj.) setpoint. Occupants may further adjust the Normal setpoint via the local sensor setpoint adjustment (the range of adjustment shall be configurable via the BAS, initially +/-2F). The BAS shall automatically apply an offset for cooling and heating set points during occupied periods as follows:

- Space cooling setpoint shall be the Normal space temperature setpoint plus 2F (adj.).
- Space heating setpoint shall be the Normal space temperature setpoint minus 2F (adj.).

During periods of unoccupied operation (space is scheduled unoccupied or no occupancy is detected for a preset period) the operator may adjust Setback heating (50F adj.), and Setback cooling (85F adj.) setpoints. The BAS will prevent the operator from entering a Setback heating setpoint higher than the Space heating setpoint OR entering a Setback cooling setpoint lower than the Space cooling setpoint.

Occupancy Override: Occupancy override shall be initiated at the local zone sensor or via the occupancy sensor. Unit shall change to the occupied mode whenever the override button is depressed (or signal is received from the occupancy sensor) for a period of 2 hours (adj.) and reset to normal operation at the end of the period or whenever the override button is held for more than 5 seconds (adj.).

Occupancy Sensor:
 GENERAL: Occupancy sensors shall be dual-technology (PIR / Ultrasonic) ceiling and/or wall mounted based on space size, configuration and use. Multiple sensors shall be networked to provide full coverage of any controlled space with 20% overlap. An isolated relay contact shall be provided for each controlled space designated for BAS monitoring.

OCCUPIED MODE SENSING: Once scheduled occupancy is established the BAS shall monitor the occupancy sensor contact and adjust the space temperature set point as follows:

- Sensor detects occupancy during occupied period:
 - BAS shall maintain normal occupancy set points.
- Sensor indicates no occupancy during occupied period:
 - Every continuous 15 minute (adj.) period after non-occupancy the normal space set points shall be reset 25% (adj.) toward their unoccupied set point. (i.e. 72F normal cooling, 80F setback cooling; after first 15 minutes set point adjusts to 74F)
 - When occupancy is detected during occupied period set points shall reset to normal occupied schedule.
- Sensor detects occupancy during unoccupied period:
 - BAS shall initiate an occupancy override and reset to normal occupancy set points.

Fan: Fan shall be enabled and run continuously during occupied mode. During unoccupied mode, fan shall be deenergized except as required to maintain setback temperature setpoints for both heating and cooling with a cycle differential of 3F (adj.). BAS shall prove fan operation and use the status indication to accumulate runtime.

- Heat Pump:** BAS shall control operation of the heat pump as follows:
- Compressor:** When the compressor is required to run, and OA temperature is greater than 0F (adj.), BAS shall enable the compressor.
 - Reversing Valve:** BAS shall control cycling of the reversing valve as required, based on the mode of operation. Reversing valve shall be energized for cooling mode. Once the valve is energized for cooling it will stay energized until a heating cycle is initiated. The reversing valve operation will be delayed after compressor shutdown to reduce noise due to refrigerant migration. In the event of a power failure the reversing valve will fail to the heating mode.
 - Safeties:** Heat pump unit shall start, stop, and protect the compressors via unit mounted controls. Refer to the specification on the respective unit for the unit mounted controls and safeties. BAS Enable/disable logic shall include a minimum on/off cycle delay of 3 minutes (adj.).
 - Cooling Mode:** Whenever the unit is energized and fan status is proven, BAS shall energize the reversing valve and enable the compressor as required to maintain space temperature cooling setpoint.
 - Heating Mode:** Whenever the unit is energized and fan status is proven, BAS shall de-energize the reversing valve and enable the compressor as required to maintain space temperature heating setpoint.

Electric Heat: Whenever the unit is energized, fan status is proven, heating is required and space temperature falls 3F (adj.) below effective heating setpoint for 15 minutes (adj.) or the compressor is locked out because of OA temperature, BAS shall enable electric heat.

LOGIC VARIABLES

BINARY	ANALOG	DESCRIPTION	#
[Occ]		ON WHEN UNIT IS INDEXED TO OCCUPIED MODE	5
[OCS]		ON WHEN OCCUPANCY SENSOR IS ACTIVE	3
[OAOK]		ON WHEN OUTSIDE AIR TEMPERATURE IS GREATER THAN SETPOINT	3
[GO]		ON WHEN THE FAN IS ENERGIZED AND STATUS IS PROVEN	3
[Temp]		VARIABLE VALUE OF CURRENT ZONE TEMPERATURE	3
[HTSP]		VARIABLE VALUE OF ACTIVE HEATING SETPOINT	2
[CLSP]		VARIABLE VALUE OF ACTIVE COOLING SETPOINT	2

ELECTRIC LADDER DIAGRAMS

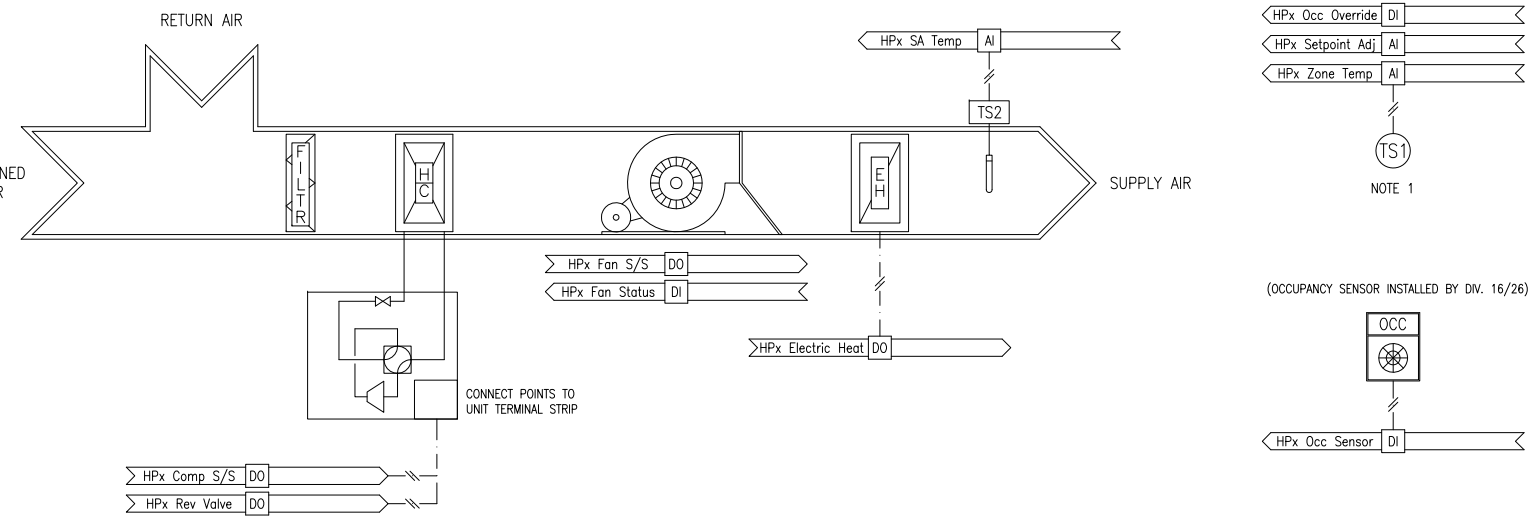
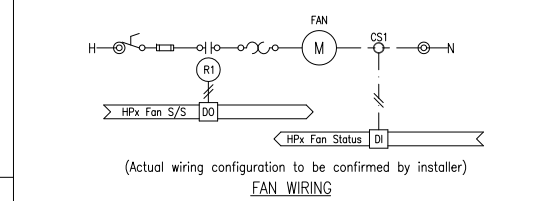

CONTROL SCHEMATIC

FAN AND SETPOINT CONTROL

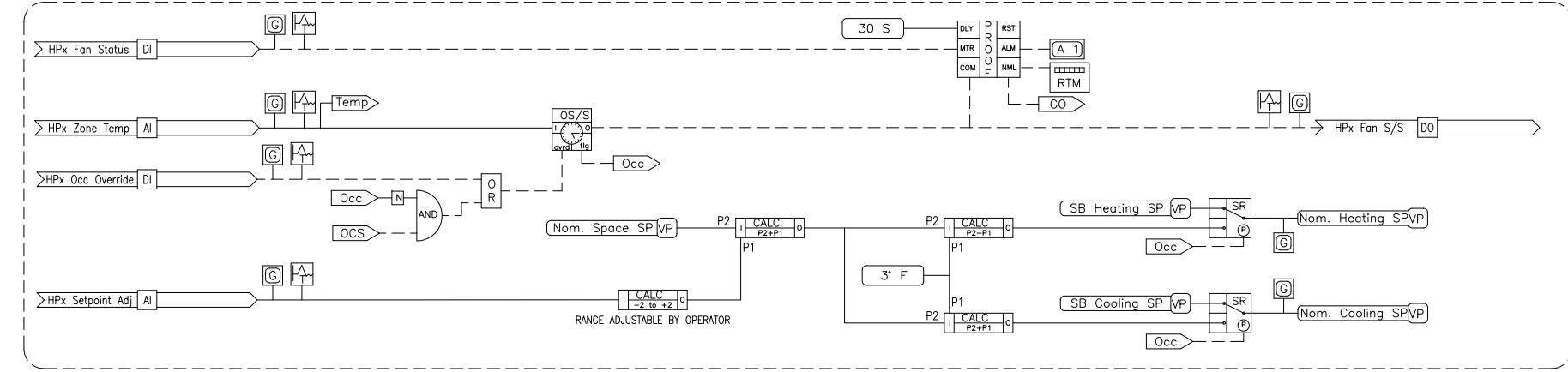

HEAT PUMP CONTROL

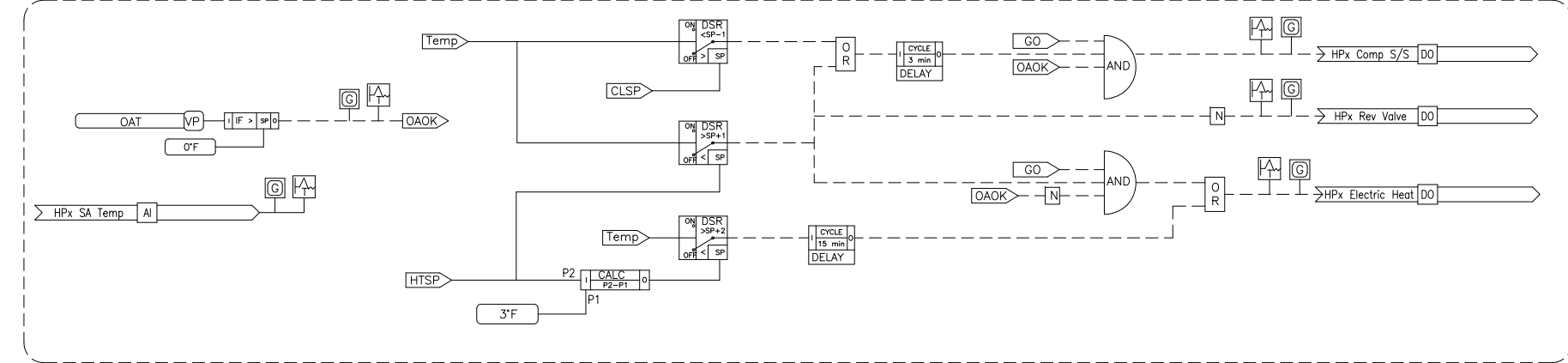

OCCUPANCY SENSOR SET POINT CONTROL

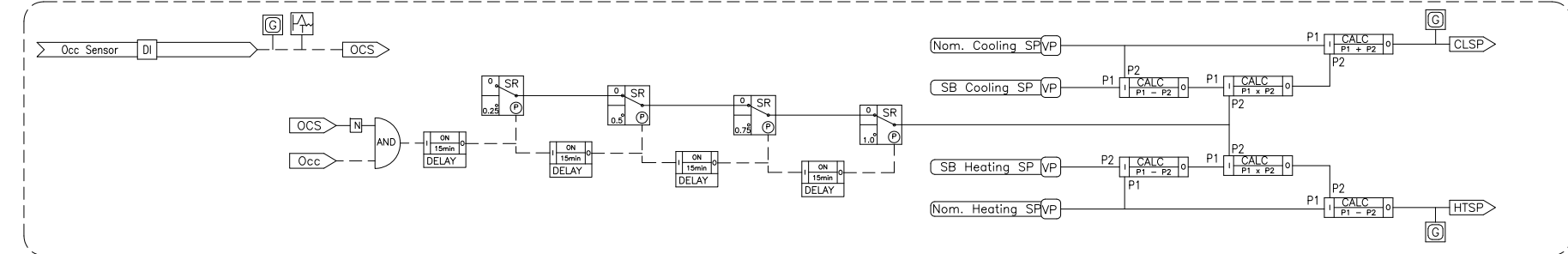

CONTROL LOGIC